

DEWALT®

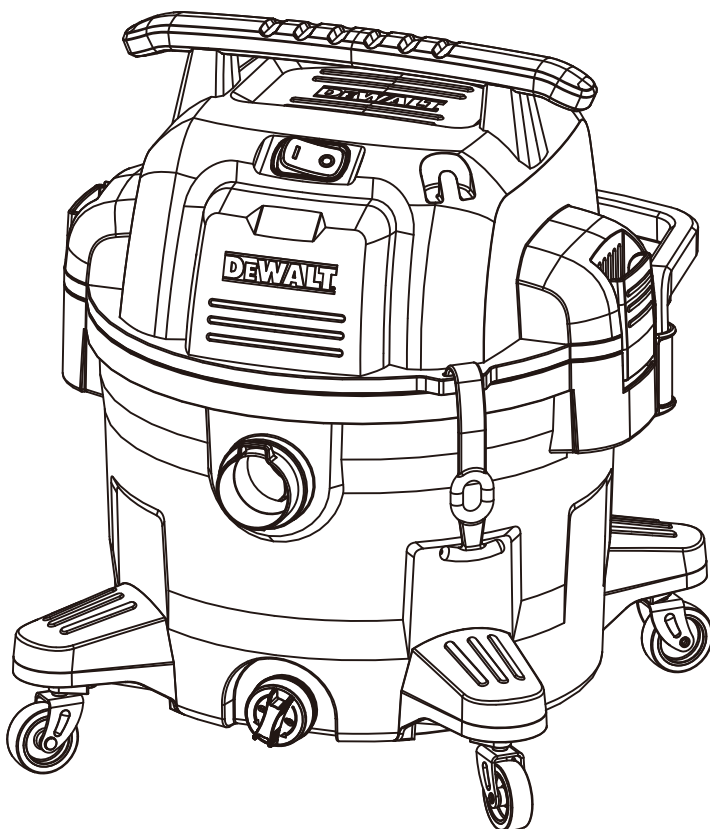

www.DEWALT.com

DXV34P

EXPRESS WARRANTY

Dear Customer,

Thank you for purchasing this DEWALT Wet & Dry Vacuum Cleaner which has passed through our extensive quality assurance processes. Every care has been taken to ensure that it reaches you in perfect condition. However, in the unlikely event that you should experience a problem, or if you require any assistance please do not hesitate to contact us.

Mayo Hardware PTY LTD (Mayo Hardware) is an authorised DEWALT Importer and Distributor of DEWALT Wet and Dry Vacuum Cleaner Models, not including DEWALT Dust Extraction Models, in Australia and New Zealand.

These DEWALT Wet and Dry Vacuum Cleaner Models are imported under license from Alton Industries Ltd Group (Alton) for DEWALT Industrial Tool Company by Mayo Hardware. All warranties relating to DEWALT Wet and Dry Vacuum Cleaner Models only, are covered in Australia and New Zealand by Mayo Hardware. DEWALT and the DEWALT Logo are trademarks of the DEWALT Industrial Tool Co., or an affiliate thereof and are used under license by Alton.



If you have a problem, call customer service; do not return this DEWALT Wet & Dry Vacuum Cleaners to the place of purchase.

CUSTOMER SERVICE

Australia: 1300 360 211

New Zealand: 09 415 6240

Operating times: Monday – Friday

8am - 5pm Australian Eastern Standard Time (AEST)

EXPRESS WARRANTY STATEMENT - DEWALT Wet & Dry Vacuum Cleaners

You are not required to do anything to register your DEWALT Wet & Dry Vacuum Cleaner purchase. Please attach your purchase receipt to this manual and ensure both are kept safe. We hope you enjoy your new DEWALT Wet & Dry Vacuum Cleaner, and if you have any problems call customer service on the above phone numbers. Do not return to place of purchase.

Mayo Hardware warrants that this DEWALT Wet & Dry Vacuum Cleaners will be free from manufacturing faults or defects for various periods as noted below, all from the date of purchase, providing original purchase receipt is kept and shown when needed and is subject to the exclusions and terms and conditions below.

The Warranty Periods;

- The actual DEWALT Product motor and motor housing are covered by a 3 year service warranty with exclusions noted in the complete warranty statement.
- The actual DEWALT Wet and Dry Vacuum Cleaner poly tub only is covered by a 10 year service warranty with exclusions noted in the complete warranty statement.

If a warranty fault appears within the warranty period, Mayo Hardware reserves the right to replace or repair the DEWALT Wet & Dry Vacuum Cleaner. If the event arises that Mayo Hardware chooses to replace the Wet & Dry Vacuum Cleaner during the any warranty period, then the warranty period is not extended beyond the original warranty end date as calculated from the purchase date on the original Tax Receipt or purchase receipt. If the Wet & Dry Vacuum Cleaner includes various accessories or components, only the defective accessory or component will be replaced or repaired.

Mayo Hardware reserves the right to replace defective parts of the DEWALT Wet & Dry Vacuum Cleaner with parts and components of similar quality, grade and composition where an identical part or component is not available.

DEWALT Wet & Dry Vacuum Cleaners presented for repair may be replaced by refurbished DEWALT Wet & Dry Vacuum Cleaners of the same type rather than being repaired. Refurbished parts may be used to repair the DEWALT Wet & Dry Vacuum Cleaners.

What is covered.

- Manufacturing fault or defect.

EXPRESS WARRANTY

How to claim under this warranty

- *Call customer service, Australia: 1300 360 211 or New Zealand: 09 415 6240*
- *Ensure you have the following: Original purchase receipt, Model of DEWALT Wet & Dry Vacuum Cleaner, serial number of DEWALT Wet & Dry Vacuum Cleaner.*
- *The customer service agent will attempt to diagnose the problem over the phone.*
- *If the issue cannot be rectified over the phone, the vacuum is to be taken to an authorised service agent. Mayo Hardware's customer service will advise which authorised service agent to take the DEWALT Wet & Dry Vacuum Cleaner to, provided the issue is covered under warranty.*
- *Take your DEWALT Wet & Dry Vacuum Cleaner to authorised service agent for repair.*

What is not covered, for a full list please read the complete warranty statement.

- *Damage or deterioration due to transport.*
- *Damage caused by negligence, misuse, abuse, accident or incorrect voltage and wattage.*
- *Any corrosion or rusting.*
- *Replacement parts due to general wear and tear.*
- *DEWALT Wet & Dry Vacuum Cleaners with no original purchase receipt.*
- *DEWALT Wet & Dry Vacuum Cleaners which have been on sold, not original purchaser.*
- *Damage caused by vacuuming hot ash or hot debris.*
- *Blockages / damage caused by a build-up of concrete dust, timber debris or other debris due to not cleaning regularly.*
- *Loan DEWALT Wet & Dry Vacuum Cleaner whilst servicing is carried out.*
- *Loss of income due to warranty servicing.*
- *DEWALT Wet & Dry Vacuum Cleaners purchased outside of, or parallel imported into, Australia or New Zealand.*
- *DEWALT Wet & Dry Vacuum Cleaners purchased from an unauthorised DEWALT reseller, including on-line trading companies or individuals (e.g. Trading Post, Amazon, eBay etc) that are not authorised DEWALT resellers in Australia, New Zealand.*

CONTACT DETAILS

Mayo Hardware PTY LTD

Australia: 1300 360 211

New Zealand: 09 415 6240

customerservice@mayohardware.com.au

Fig. A

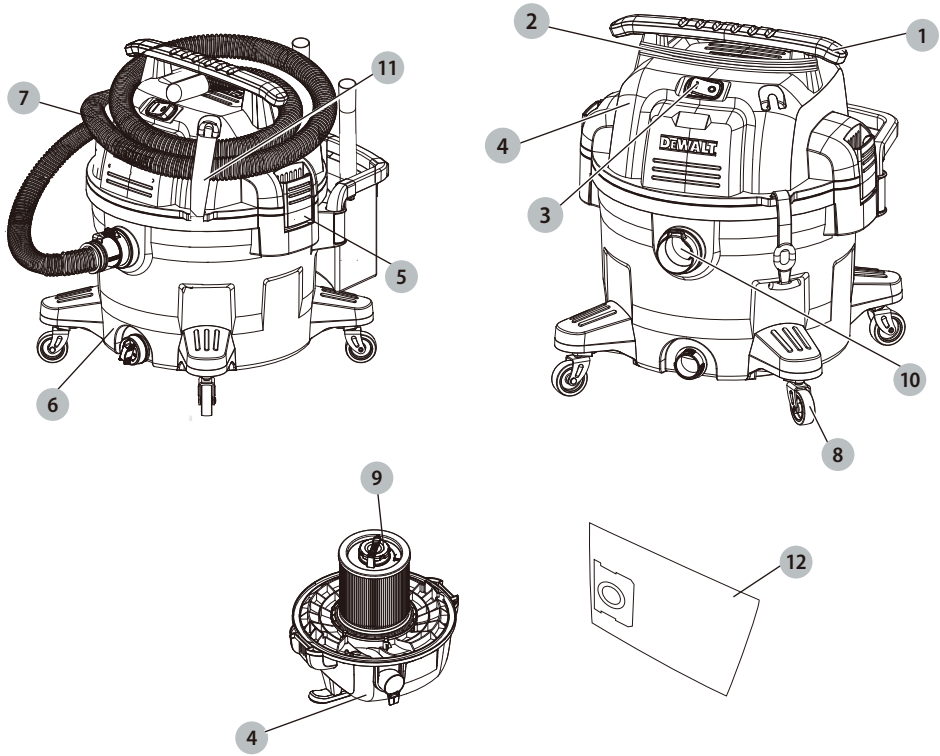

Fig. B

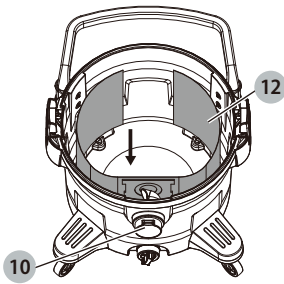

Fig. C

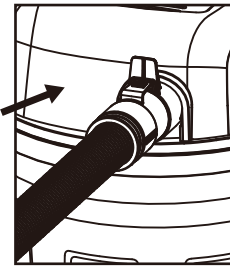

Fig. D

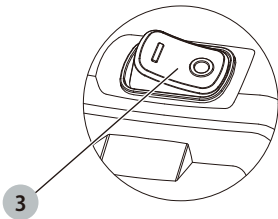

Fig. E

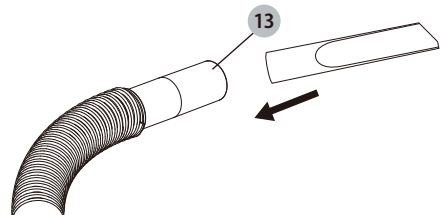

Fig. F

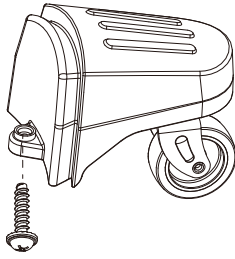

Fig. G

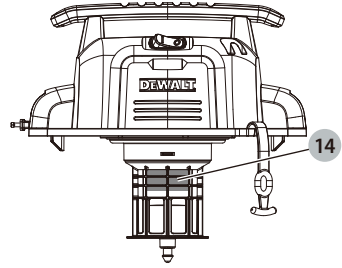

Fig. H

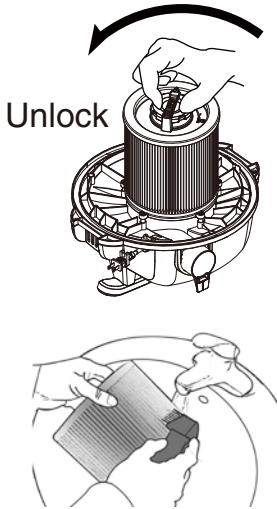

Fig. I

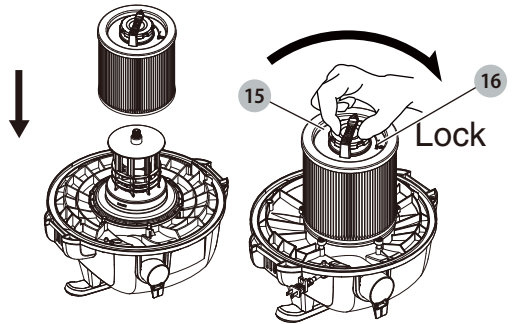
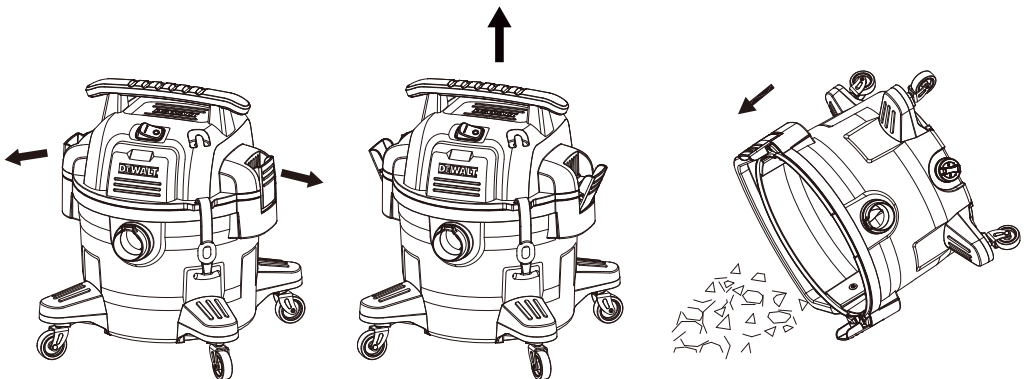

Fig. J



PRODUCT SPECIFICATIONS

Model	DXV34P
Voltage	240V
Frequency	50Hz
Wattage	1200W
Seal pressure	17 Kpa
Air flow	42.5 L/S
Tank capacity	34 L
Power cord	H05RN-F,2Cx0.75mm ² / 3m. Length

Noise values according to EN60335-2-69

L _{PA} (emission sound pressure level)	78dBA
L _{WA} (sound power level)	91dBA

Package Contents

The package contains:

- 1 48mm x 2.1m Vacuum Hose
- 1 Extension Wand (x2)
- 1 Crevice Nozzle
- 1 Utility Nozzle
- 1 Accessory Bag
- 1 Disposable Dust Bag
- 1 Clean Connect™ Filter
- 1 Floor Nozzle
- 1 Instruction Manual
- 1 Round Brush

- Check for damage to the tool, parts or accessories which may have occurred during transport.
- Take the time to thoroughly read and understand this manual prior to operation.

DEFINITIONS: SAFETY GUIDELINES

The definitions below describe the level of severity for each signal word. Please read the manual and pay attention to these symbols.

▲ DANGER: Indicates an imminently hazardous situation which, if not avoided, **will** result in **death or serious injury**.

▲ WARNING: Indicates a potentially hazardous situation which, if not avoided, **could** result in **death or serious injury**.

▲ CAUTION: Indicates a potentially hazardous situation which, if not avoided, **may** result in **minor or moderate injury**.

NOTICE: Indicates a practice **not related to personal injury** which, if not avoided, **may** result in **property damage**.

IMPORTANT SAFETY INSTRUCTIONS

▲ WARNING: When using electric appliances, always follow basic safety precautions to reduce the risk of fire, electric shock and personal injury, including the following:

BEFORE USING THIS APPLIANCE, READ AND FOLLOW ALL INSTRUCTIONS.

▲ WARNING: To reduce the risk of electric shock. Do not expose to rain. Store indoors.

- Do not leave the appliance when it is connected to a power source. Unplug it from outlet when not in use and before servicing.
- Do not allow the appliance to be used as a toy. Pay close attention when the appliance is used by or near children.
- Use this appliance **ONLY** as described in the manual. Use only DEWALT recommended attachments.
- Do not use this appliance with a damaged cord or plug. If the appliance is not working correctly, or if it has been dropped, damaged, left outdoors, or dropped in water, return it to a service centre.
- Do not pull or carry this appliance by the cord, use the cord as a handle, close a door on the cord, or pull the cord around sharp edges or corners. Do not run the appliance over the cord. Keep cord away from heated surfaces.
- Do not unplug this appliance by pulling on the cord. To unplug, grasp the plug, not the cord.
- Do not handle the plug or appliance with wet hands.
- Do not put any objects into the openings of the appliance. Do not use the appliance with any opening blocked; keep free of dust, lint, hair and anything else that may reduce air flow.
- Keep hair, loose clothing, fingers, and all body parts away from the openings and moving parts.
- Turn off all controls before unplugging appliance.
- Use extra care when cleaning on stairs.
- Do not use the appliance to pick up flammable or combustible liquids, such as gasoline, or use in areas where flammable or combustible liquids are present.
- Static shocks are possible in dry areas or when the relative humidity of the air is low. This is only temporary and does not affect the use of the vacuum. To reduce the frequency of static shocks, add moisture to the air with a console, installed humidifier or use anti-static hose (standard on some models).
- To avoid spontaneous combustion, empty canister after each use.
- **▲ CAUTION:** This appliance is not intended for use by persons (including children) with reduced physical, sensory or mental capabilities, or lack of experience and knowledge, unless they have been given supervision or instruction concerning use of the appliance by a person responsible for their safety. Children should be supervised to ensure that they do not play with the appliance.

**SAVE THESE INSTRUCTIONS
ADDITIONAL SAFETY RULES**

- Do not pick up anything that is burning or smoking, such as cigarettes, matches, or hot ashes.
- Do not use to vacuum combustible explosive materials, such as coal, grain, or other finely divided combustible material.
- Do not use to vacuum hazardous, toxic or carcinogenic materials, such as asbestos or pesticide.
- Never pick up explosive liquids (e.g. gasoline, diesel fuel, heating oil, paint thinner, etc.), acids or solvents.

English

- Do not use vacuum without filters in place, except as described under **Wet Pickup Applications**.
- Some wood contains preservatives which can be toxic. Take extra care to prevent inhalation and skin contact when working with these materials. Request and follow any safety information available from your material supplier.
- Do not use vacuum as a step ladder.
- Do not place heavy objects on vacuum.
- An extension cord must have adequate wire size for safety.
- If an extension cord is to be used outdoors it must be marked.

▲ WARNING!

To reduce your exposure to these chemicals, wear approved safety equipment such as dust masks that are specifically designed to filter out microscopic particles. For your convenience and safety, the following warning labels are on your vacuum.

ON MOTOR HOUSING :

▲ WARNING!

- TO REDUCE THE RISK OF INJURY, USER MUST READ INSTRUCTION MANUAL. DO NOT RUN UNATTENDED. DO NOT PICK UP FLAMMABLE, COMBUSTIBLE OR HOT MATERIALS. DO NOT USE AROUND EXPLOSIVE DUST, LIQUIDS OR VAPORS. ELECTRICAL DEVICES PRODUCE ARCS OR SPARKS WHICH CAN CAUSE FIRE OR EXPLOSION. DO NOT USE AT FILLING STATIONS OR ANYWHERE GASOLINE IS STORED OR DISPENSED. DO NOT VACUUM TOXIC OR CARCINOGENIC MATERIALS OR OTHER HEALTH ENDANGERING MATERIAL SUCH AS ASBESTOS OR PESTICIDES. ALWAYS USE PROPER EYE AND RESPIRATORY PROTECTION. TO REDUCE THE RISK OF ELECTRICAL SHOCK, DO NOT EXPOSE TO RAIN. STORE INDOORS. WHEN SERVICING, USE ONLY IDENTICAL REPLACEMENT PARTS. NOT TO BE USED AS A STEP STOOL.

SAVE THESE INSTRUCTIONS

OPERATING INSTRUCTIONS

UNPACKING & SET-UP SUMMARY

1. Pull lid latches in an outward motion, remove power head and some accessories that may have been shipped in the tank.
2. Attach heavy-duty rubberised casters following the instructions in this manual.
3. Before replacing power head, refer to this manual to ensure you have the proper filters installed for your cleaning operation.
4. Replace power head, and apply pressure with thumb to each latch until it snaps tightly in place. Make sure all lid latches are clamped securely.
5. Insert the air hose end into inlet of tank.
6. Attach the extension wands to the accessory end of

- the hose. Apply slight pressure until fitting is tight.
7. Attach one of the cleaning accessories (depending on your cleaning requirements) on the extension wands. Twist slightly to tighten the connection.
8. Plug the cord into the wall outlet. Your cleaner is ready for use.

▲ WARNING!

To reduce the risk of fire or explosion, do not operate this vac in areas with flammable gases, vapors or explosive dust in the air. Flammable gases or vapors include but are not limited to: lighter fluid, solvent-type cleaners, oil-based paints, gasoline, alcohol or aerosol sprays. Explosive dusts include but are not limited to: coal, magnesium, aluminum, and grain or gun powder. Do not vacuum explosive dust, flammable or combustible liquids or hot ashes. Do not use this vac as a sprayer for any flammable or combustible liquid. To reduce the risk of health hazards from vapors or dusts, do not vacuum toxic materials.

IMPORTANT SAFEGUARDS

The symbol on the product or packaging indicates that the product must not be treated as domestic refuse. Instead, it should be handed in to a collection point for the recycling of electrical and electronic components. By ensuring the product is treated in the correct manner, you will help prevent any negative impact on your health and the environment that might arise were the product to be discarded as ordinary refuse. For further information about recycling, you should contact your local authorities, refuse collection service or the sales outlet where you bought the goods.

Protecting the environment



Separate collection. Products and batteries marked with this symbol must not be disposed of with normal household waste.

Products and batteries contain materials that can be recovered or recycled reducing the demand for raw materials. Please recycle electrical products and batteries according to local provisions. Further information is available at www.2helpU.com

Description (Fig. A)

▲ WARNING : Never modify the power appliance or any part of it. Damage or personal injury could result.

- 1 Top handle/cord wrap
- 2 Power cord
- 3 On/off power switch
- 4 Vacuum head
- 5 Canister latch
- 6 Canister
- 7 Suction hose
- 8 Casters
- 9 Filters
- 10 Threaded hose inlet
- 11 Hose strap
- 12 Bag

ASSEMBLY AND ADJUSTMENTS (Fig. A-C)

▲ WARNING: To reduce the risk of injury, turn appliance off and disconnect appliance from power source before installing and removing accessories, before adjusting or changing set-ups or when making repairs. An accidental start-up can cause injury.

▲ WARNING: The filters **9** must always be in place while vacuuming, except as described under **Wet Pick Up Applications** under **Operation**.

When vacuuming fine dust, you may also use an additional paper bag or fleece bag to make emptying the canister easier.

1. If optional paper or fleece bag **12** is to be used, install as shown in Figure B.

NOTE: Be careful not to tear the bag. Place bag securely onto inlet **10** to provide a tight seal for maximum dust collection performance.

2. Place the vacuum head **4** onto the canister and secure it by closing the canister latches **5**.
3. Insert end of hose **7** into threaded hose inlet **10** and tighten the end of hose on to the tank.

OPERATION

Instructions for Use (Fig. A, D, E)

▲ WARNING: Always observe the safety instructions and applicable regulations.

▲ WARNING: To reduce the risk of injury, turn appliance off and disconnect appliance from power source before installing and removing accessories, before adjusting or changing set-ups or when making repairs. An accidental start-up can cause injury.

1. Plug the power cord into an appropriate outlet.
2. Turn the on/off switch **3** to the ON position (I).
3. Your DEWALT construction dust extractor is fitted with the DEWALT connection system. This allows for a fast, secure connection between the hose **7** and power tool. The connector **13** connects

directly to DeWALT compatible tools or through the use of an adapter (available from your local DEWALT supplier). Refer to the Accessories section for detail on available adapters.

NOTE: If using an adapter ensure it is firmly attached to the tool outlet before following the steps below.

OPERATING INSTRUCTIONS

Caster installation (Fig. A, F)

1. Invert dust tank, take the dolly to align the tank bottom sinking place. Secure with screws provided.
2. Return dust tank assembly upright.

Remove / Change Used Dust Collection Bag (Fig. A)

▲ WARNING: Appropriate personal protective equipment like dust mask and gloves should be used while handling used dust bags.

1. Turn off vacuum and unplug cord from outlet.
2. Unlatch canister latches **5** and remove vacuum head **4**.
3. Pull the collection bag carefully from inlet **10**.
4. Seal the collection bag opening tightly when removing it from the machine.
5. Dispose of collection bag in appropriate container according to statutory provisions.

Wet Pick Up Applications (Fig. A, G)

▲ WARNING: If foam or liquid escapes from the machine, switch off immediately.

▲ CAUTION: Clean the water level limiting device regularly and examine it for signs of damage.

Refer to Fig. G.

▲ NOTICE: DO NOT remove ball float **14**, doing so will cause damage to the vacuum. The ball float keeps water from entering the motor.

Before using the vacuum for wet pick up:

- Ensure the canister is empty and free of excessive dust.
- Remove filters **9**.

▲ WARNING: Do not use the machine with this set up for dust Class L.

To Empty Canister (Fig. A, G)

The ball float valve **14** will block air to the motor when the canister is full and the sound of the motor will change at once.

When the motor has a high pitched sound and air/water flow stops, empty the canister.

1. Turn off vacuum and unplug cord from outlet.
2. Unlatch canister latches **5** and remove vacuum head **4**.
3. Empty contents of canister **6** into a suitable container or drain.

To Convert Back to Dry Vacuum Operation (Fig. A)

1. Empty Canister, refer to Empty Canister instructions.

English

2. Place canister upside down position until dry. DO NOT use wet canister for dry pick up.
3. Place vacuum head 4 on a level surface until dry.
4. Reinstall filters when vacuum head is dry. See Filters under Maintenance.
5. When canister is dry place the vacuum head 4 onto the canister and secure it by closing the canister latches 5.

Shut Down/Transportation (Fig. A)

1. Turn on/off control switch 3 to the OFF position.
2. Unplug the unit.
3. Store the power cord 2 wrapping it around the top handle/cord wrap 1 as shown.
4. When transporting in vehicles, secure the machine.

MAINTENANCE

Your DEWALT appliance has been designed to operate over a long period of time with a minimum of maintenance care. Continuous satisfactory operation depends upon proper appliance care and regular cleaning.

▲ WARNING: To reduce the risk of injury, turn appliance off and disconnect appliance from power source before installing and removing accessories, before adjusting or changing set-ups or when making repairs. An accidental start-up can cause injury.

▲ WARNING: For user servicing, the machine must be dismantled, cleaned and serviced, as far as is reasonably practicable, without causing risk to the maintenance staff and others. Suitable precautions include, decontamination before dismantling, provision for local filtered exhaust ventilation where the machine is dismantled, cleaning of the maintenance area and suitable personal protection.

- The manufacturer, or an instructed person, shall perform a technical inspection at least annually, consisting of, for example, inspection of the filter for damage, air tightness of the machine and proper function of the control mechanism.
- When carrying out service or repair operations, all contaminated items which cannot be satisfactorily cleaned, are to be disposed of; such items shall be disposed of in impervious bags in accordance with any current regulation for the disposal of such waste.

(NOTE: Reference to National Regulations is necessary.)

Filter (Fig. A, H, I)

Filter care

The filters included with this vacuum are long life filters. To be effective in minimising dust recirculation, the filters MUST be installed correctly and in good condition.

▲ WARNING: Appropriate personal protective equipment like dust mask and gloves should be used while handling the filters.

To Remove Filters

1. Turn on/off control switch 3 to the OFF position (O) and unplug cord from outlet.
2. Release canister latches 5 and remove vacuum head 4 from canister. Place vacuum head on a level surface upside down.
3. Turn each filter 9 counterclockwise by gripping it on the plastic end cover as shown, and carefully remove from head, ensuring debris does not fall into mounting hole.

NOTE: Use care to not damage filter material.

4. If the bottom side of the vacuum head 4 needs to be cleaned, use a cloth dampened with water and mild soap and allow it to dry. Dispose of cloth in an appropriate container.
5. Inspect filters for wear, tears or other damage.

NOTE: If there is any doubt on the condition of the filters they MUST be replaced. DO NOT continue use if filters are damaged.

▲ WARNING: Never use compressed air or a brush to clean filters, otherwise damage to the filter membrane will occur which will allow dust to pass through the filter. If needed, gently tap against a hard surface or rinse with room temperature water and let air dry. Cleaning of the filters is typically unnecessary, even if the filter is covered with dust. The automatic filter cleaning system will maintain maximum performance and continue to function. If visual damage to the filter membrane exists, replace filters. Filters typically last between six and twelve months depending on use and care.

To Install Filters

1. Ensure filter seal 15 is in place and is secure.
2. Line up filter threads 16 to vacuum head threads and using moderate force, turn filter clockwise until tight.

NOTE: Use care to not damage filter material.

3. Place the vacuum head 4 onto the container and secure it by closing the canister latches 5.

Empty The Tank (Fig. J)

▲ WARNING: To reduce the risk of injury from accidental starting, unplug power cord before emptying the dust tank.

1. Remove the power head assembly of the wet/dry vac by pulling outward on the lid clips located on each side of the vac. Lift off the power head assembly.
2. Dump the tank contents into the proper waste disposal container.

BLOWING OPERATION

▲ WARNING: To avoid injury to bystanders, keep them clear of blowing debris.

▲ CAUTION: Wear a dust mask if blowing creates dust which might be inhaled.

▲ CAUTION: To reduce the risk of hearing loss, wear ear protectors when using the vac/blower for extended hours or when using it in a noisy area.

Blowing Feature (Fig. C)

Your vac contains a blowing feature. It has the capability to blow sawdust and other debris. It can be used to blow dust and debris out of garages or off patios and driveways. Follow the steps below to use your vac as a blower.

1. Locate blowing port on your vac.
2. Insert one end of the 48mm x 2.1m hose into the blowing port.
3. Turn vacuum "ON".

Storage (Fig. A)

1. Empty the canister, refer to Empty Canister under Operation.
2. Clean the vacuum inside and outside. Refer to Cleaning.
3. Clean or replace filters, refer to Filters.
4. Store the suction hose and the power cord as shown in the illustration. Place the unit in a dry room and secure it from unauthorised use.

Optional Accessories

▲ WARNING: Since accessories, other than those offered by DEWALT, have not been tested with this product, use of such accessories with this appliance could be hazardous.

To reduce the risk of injury, only DEWALT recommended accessories should be used with this product.

CLEANING

To keep your wet/dry vac looking its best, clean the outside with a cloth dampened with warm water and mild soap.

To clean the tank:

1. Dump out debris.
2. Wash tank thoroughly with warm water and mild soap.
3. Wipe out with dry cloth.

TROUBLESHOOTING

▲ WARNING!
TO REDUCE THE RISK OF INJURY FROM MOVING PARTS AND/OR ELECTRICAL SHOCK, TURN POWER SWITCH OFF AND DISCONNECT GROUNDED PLUG FROM ELECTRICAL OUTLET BEFORE PERFORMING TROUBLESHOOTING CHECKS.

Minor problems often can be fixed without calling customer service.

PROBLEM	SOLUTION
Motor does not run	Check power cord, plugs and outlet.
	Ensure the on/off switch is in the ON position (I)
Suction capacity decreases	Remove blockages in the suction nozzle, suction tube, suction hose or filters.
	Replace the paper or fleece bag.
	Check for proper installation of the filters.
	Clean or replace the filters.
Vacuum stops running	Empty canister, refer to Empty the tank under Operating instructions
	Thermal overload has been tripped: 1. Turn the vacuum off and disconnect vacuum cleaner from power source. 2. Empty the canister, if needed. 3. Allow the unit to cool. 4. Plug the power cord into an appropriate outlet and turn on/off switch to the ON position (I) to test.
Dust comes out while vacuuming	Check for proper installation of the filters.
	Ensure filters are not damaged; replace if necessary.
	Ensure filter seals are in place and are secure.

▲ WARNING! If the power cord is damaged, it must be replaced by the manufacturer, its service agent or similarly qualified persons in order to avoid a hazard.



WARRANTY

COMPLETE WARRANTY STATEMENT – DEWALT WET & DRY VACUUM CLEANER

As soon as you have purchased the DEWALT Wet & Dry Vacuum Cleaner, we recommend that you check to make sure it is intact and that you read the operating instructions carefully before using it. The purchase receipt for this DEWALT Wet and Dry Vacuum Cleaner is to be retained and must be presented if making a claim under the terms of the Mayo Hardware PTY LTD (Mayo Hardware) warranty. Bank account statements are not acceptable for proof of purchase.

Mayo Hardware is an authorised DEWALT Importer and Distributor of DEWALT Wet and Dry Vacuum Cleaner Models, not including DEWALT Dust Extraction Models, in Australia and New Zealand. These DEWALT Wet and Dry Vacuum Cleaner Models are imported under license from Alton Industries Ltd Group (Alton) for DEWALT Industrial Tool Company by Mayo Hardware. All warranties relating to DEWALT Wet and Dry Vacuum Cleaner Models only, are covered in Australia and New Zealand by Mayo Hardware. DEWALT and the DEWALT Logo are trademarks of the DEWALT Industrial Tool Co., or an affiliate thereof and are used under license by Alton.

The Warranty periods;

- The actual DEWALT Wet and Dry Vacuum Cleaner motor and motor housing are covered by a 3 year service warranty with exclusions noted below.
- The actual DEWALT Wet and Dry Vacuum Cleaner poly tub only is covered by a 10 year service warranty with exclusions noted below.

General warranty details for all warranty periods;

- This is a repair only warranty; after contacting our customer service centre you will need to take your DEWALT Wet and Dry Vacuum Cleaner to the authorised service agent.
- If in the event of Mayo Hardware choosing to replace the appliance, the warranty will not be extended beyond the original purchase contract warranty period.
- The warranty will under no circumstances extend to reimbursement or payment of damages, whether direct, indirect or consequential.
- The warranty is void if there is evidence the DEWALT Wet and Dry Vacuum Cleaner has been modified or tampered with in any way or used with unauthorised accessories.
- Mayo Hardware declines any responsibility or liability whatsoever arising from misuse or abuse, negligent handling of the DEWALT Wet and Dry Vacuum Cleaners or if the DEWALT Wet and Dry Vacuum Cleaner has not been assembled correctly or failure to comply with the relevant safety, operating, setting and maintenance instructions (see further details in this manual).
- The warranty does not cover any fuel costs or personal transport costs associated with returning your DEWALT Wet and Dry Vacuum Cleaner for either assessment, repair, service, replacement or credit.
- Any item sent freight forward/collect for repair will be refused.
- Warranty repairs are free of charge, provided the appliance is delivered to an authorised Mayo Hardware service agent. The DEWALT Wet and Dry Vacuum Cleaner will need to be returned, adequately protected in a box. Mayo Hardware will not be responsible for any in-transit loss or damage. Assistance under the warranty will only be made available if the request is made to our customer service team on the contact numbers listed below and proof of purchase is provided.
- Where a DEWALT Wet and Dry Vacuum Cleaner is returned on pre-paid freight for assessment or service it will be reviewed accordingly. If a warranty fault is found, the freight cost will be credited to the owner. If no fault is found, the DEWALT Wet and Dry Vacuum Cleaner will be returned, and any costs associated with the service will be charged to the owner.
- If the DEWALT Wet and Dry Vacuum Cleaner includes various accessories or components, only the defective DEWALT Wet and Dry Vacuum Cleaner accessory or component will be replaced or repaired.
- Mayo Hardware reserves the right to replace defective parts of the DEWALT Wet and Dry Vacuum Cleaner with parts and components of similar quality, grade, and composition where an identical part or component is not available.
- DEWALT Wet and Dry Vacuum Cleaners presented for repair may be replaced by refurbished DEWALT Wet and Dry Vacuum Cleaners of the same type rather than being repaired. Refurbished parts may be used to repair the DEWALT Wet and Dry Vacuum Cleaners.

WARRANTY

Specific warranty details

The 3 year warranty is a service warranty and specifically excludes or does not warrant the following:

- *Damage or deterioration due to transport.*
- *Any corrosion or rusting.*
- *Damage caused by incorrect set up and start up.*
- *DEWALT Wet & Dry Vacuum Cleaners with serial number defacement, modification or removal.*
- *DEWALT Wet & Dry Vacuum Cleaners which have been serviced by other than an authorised Mayo Hardware service agent.*
- *DEWALT Wet & Dry Vacuum Cleaners with no original purchase receipt.*
- *DEWALT Wet & Dry Vacuum Cleaners which have been on sold, not original purchaser.*
- *Damage caused by vacuuming hot ash or hot debris.*
- *Blockages / damage caused by a build-up of concrete dust, timber debris or other debris due to not cleaning regularly.*
- *Damage caused by the incorrect fitting of accessories.*
- *Damage caused by accident, misuse, neglect, abuse or shipping/freight accident. For the purposes of the 3 year warranty, misuse, neglect and abuse are defined as using the DEWALT Wet and Dry Vacuum Cleaner in a manner not specified by the instruction manual.*
- *Failure or damage caused by use, misuse or abuse of non-approved accessories or attachments, including but not limited to, non-genuine accessories & attachments. For the purposes of the 3 year warranty, non-approved accessories, attachments, are defined as those not specified by the instruction manual.*
- *DEWALT Wet & Dry Vacuum Cleaners where a modification to the original DEWALT Wet & Dry Vacuum Cleaner has occurred, or where the DEWALT Wet & Dry Vacuum Cleaner casing has been opened, or where actual or attempted repair work on the DEWALT Wet & Dry Vacuum Cleaner has been carried by anyone other than an authorised Mayo Hardware service agent.*
- *Damage due to non-servicing of DEWALT Wet & Dry Vacuum Cleaners as is required by this manual.*
- *Damage caused by overloading, overworking or excessive use of the DEWALT Wet & Dry Vacuum Cleaner. For the purposes of this warranty, excessive use is deemed to have occurred when a DEWALT Wet and Dry Vacuum Cleaner is assessed by Mayo Hardware as displaying wear & tear that is considered abnormal for a DEWALT Wet and Dry Vacuum Cleaner of its age, when used in a regular manner, serviced and maintained as per the requirements of the manual and in the normal use of the DEWALT Wet and Dry Vacuum Cleaner for which it was designed for are not covered under warranty.*
- *DEWALT Wet & Dry Vacuum Cleaners purchased outside of, or parallel imported into, Australia or New Zealand.*
- *DEWALT Wet & Dry Vacuum Cleaners purchased from an unauthorised DEWALT reseller, including on-line trading companies or individuals (e.g. Trading Post, Amazon, eBay etc) that are not authorised DEWALT resellers in Australia or New Zealand.*
- *Damage to attached equipment or third-party accessories.*
- *Damage caused by attached equipment or third-party accessories.*
- *A loan DEWALT Wet & Dry Vacuum Cleaner whilst repairs or servicing is carried out is not available.*
- *Loss of income due to warranty servicing.*
- *Rebuilt, Reconditioned, Ex-Display, Factory Seconds & Blemished DEWALT Wet & Dry Vacuum Cleaners.*
- *Servicing or repairs on DEWALT Wet & Dry Vacuum Cleaners.*
- *DEWALT Service Parts for DEWALT Wet & Dry Vacuum Cleaners.*
- *DEWALT Accessories included in the carton of your DEWALT Wet & Dry Vacuum Cleaners.*

The 10 Year limited warranty ONLY applies to DEWALT Wet and Dry Vacuum Cleaners with DEWALT Orange/Yellow poly tubs. The 10 year limited warranty specifically excludes or does not warrant the following:

- *Damage or deterioration due to transport.*
- *Replacement poly tubs due to general wear and tear.*
- *DEWALT Wet & Dry Vacuum Cleaners with serial number defacement, modification or removal.*
- *DEWALT Wet & Dry Vacuum Cleaners which have been serviced by other than an authorised Mayo Hardware service agent.*

WARRANTY

- DEWALT Wet & Dry Vacuum Cleaners with no original purchase receipt.
- DEWALT Wet & Dry Vacuum Cleaners which have been on sold, not original purchaser.
- Damage caused by overloading, overworking or excessive use of the DEWALT Wet & Dry Vacuum Cleaner poly tub. For the purposes of this warranty, excessive use is deemed to have occurred when a DEWALT Wet and Dry Vacuum Cleaner poly tub is assessed by Mayo Hardware as displaying wear & tear that is considered abnormal for a DEWALT Wet and Dry Vacuum Cleaner poly tub of its age, when used in a regular manner, serviced and maintained as per the requirements of the manual and in the normal use of the DEWALT Wet and Dry Vacuum Cleaner for which it was designed for are not covered under warranty.
- DEWALT Wet & Dry Vacuum Cleaners with poly tubs purchased outside of, or parallel imported into, Australia or New Zealand.
- DEWALT Wet & Dry Vacuum Cleaners with poly tubs purchased from an unauthorised DEWALT reseller, including on-line trading companies or individuals (e.g. Trading Post, Amazon, eBay etc) that are not authorised DEWALT resellers in Australia or New Zealand.
- Damage caused by attached equipment or third-party accessories.
- A loan DEWALT Wet & Dry Vacuum Cleaner whilst repairs or servicing is carried out is not available.
- Loss of income due to warranty servicing.
- Rebuilt, Reconditioned, Ex-Display, Factory Seconds & Blemished DEWALT Wet & Dry Vacuum Cleaners with poly tubs.
- Servicing or repairs on DEWALT Wet & Dry Vacuum Cleaners, other than the actual poly tub which is not excluded with any of the other clauses.
- The 10 Year Limited Warranty period applies for 10 years from the date of purchase from an authorised DEWALT retailer. The 10 Year Limited Warranty covers the costs of labour and materials only where they are used to repair a manufacturing or material defect in the DEWALT Wet and Dry Vacuum Cleaner DEWALT Orange/Yellow poly tubs.
- The 10 Year Limited Warranty period will not be extended, if for some reason the DEWALT Wet and Dry Vacuum Cleaner with DEWALT Orange/Yellow poly tubs is replaced during or after the original 10 Year Limited Warranty period.
- All accessories or components (including those sold with the DEWALT Wet and Dry Vacuum Cleaner) and all mechanical and electrical parts of the DEWALT Wet & Dry Vacuum Cleaner other than the DEWALT Orange/Yellow poly tub.

Our goods come with guarantees that cannot be excluded under the Australian Consumer Law. You are entitled to a replacement or refund for a major failure and for compensation for any other reasonably foreseeable loss or damage. You are also entitled to have the goods repaired or replaced if the goods fail to be of acceptable quality and the failure does not amount to a major failure. The benefits of this warranty are in addition to any rights and remedies imposed by Australian State and Federal legislation that cannot be excluded.

In New Zealand, this Mayo Hardware warranty is in addition to the conditions and guarantees which are mandatory as implied by the New Zealand Consumer Guarantee Act 1993.

For service, spare parts or DEWALT Wet and Dry Vacuum Cleaner information please contact customer service:

Australia: 1300 360 211

New Zealand: 09 415 6240

CONTACT DETAILS

Mayo Hardware PTY LTD

Australia: 1300 360 211

New Zealand: 09 415 6240

customerservice@mayohardware.com.au

YELLOW & BLACK™

Copyright © 2022 DeWALT.

DeWALT® and the DeWALT Logo are trademarks of the DeWALT Industrial Tool Co., or an affiliate thereof and are used under license.

The yellow/black color scheme is a trademark for DeWALT power tools & accessories.

Due to continual product development, the product you purchase may differ slightly from the one shown here.

Do not return to place of purchase.

Mayo Hardware PTY LTD

CUSTOMER SERVICE

Australia: 1300 360 211

New Zealand: 09 415 6240

Operating times: Monday – Friday

8.00am - 5.00 pm Australian Eastern Standard Time (AEST)